



RMG AUTOMATION

+91 9940594413

Fully Automatic Water Level Controller

Model : FAWLC-020

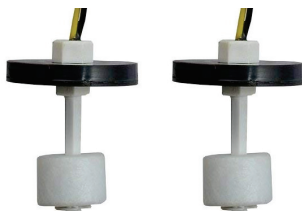

User Manual

1. INTRODUCTION

Water saving is lifesaving. RMG Automation introduces its latest model of wired water level controller. Fully Automatic Water Level Controller automatically turns ON motor when tank is empty and turns OFF motor when tank is fully filled. It also has dry run, L/H voltage protection to save your motor. FAWLC-020 has two level indicators. This product is suitable for Bore well to Tank setup.

2. DESCRIPTION

- **Power ON/OFF switch:** This switch is provided at the left side to switch ON/OFF the controller unit.
- **Power ON LED:** It indicates the power supply to the unit.
- **Low/High Voltage LED:** It indicates Low/High Voltage power supply. Motor pump gets switched off and is protected from such condition.
- **Dry Run LED:** It indicates the dry run of the motor pump. If there is no water flow in the inline pipe of the overhead tank for 1 minute, motor gets switched OFF preventing it from Dry Run.
- **Motor ON LED:** It indicates the motor ON condition.
- **Tank Level Indication:** used to indicate water levels. (FAWLC-020 has 25% and 100% indications)
- **Manual/Auto mode switch:**
 - **Auto mode:** In AUTO mode, motor will automatically switch ON when the water level in the tank is low and automatically switch OFF when the tank becomes full
 - **Manual Mode:** Helps to switch ON the motor manually. In this mode, the motor will be constantly running.
 - **Semi-Automatic** (Manual ON and Auto OFF) Just keep the controller in MANUAL mode for the motor to get switched ON and then change it to AUTO mode for Automatic OFF.

3. TOOLS REQUIRED

- 2 pair or 4 core communication cable.
- Drilling Machine
- Simple hammer
- Wooden gattas
- Screws for mounting units on wall
- Line tester
- Wire stripper,
- 1.5Sq.mm Wire for power connections
- Insulation tape

4. INSTALLATION PROCEDURE

Caution: Switch off the main power while doing the Power Connection steps.

Step 1: Wall mount the Controller unit nearby motor pump switch/starter location.

Step 2: As per the model purchased, check the label and connect AC supply (230V / 440 V) to 1st and 2nd terminal of the controller (red and black wire) refer figure 1 and figure 2.

Step 3: For switch or MCB, Connect 3rd and 4th terminal of the controller (blue pair wire) to the switch/MCB of the motor in parallel as shown in figure 1.

Step 4: For starter, Connect 3rd and 4th terminal of the controller (blue pair wire) to ON button of starter in parallel and 5th and 6th terminal (black pair wire) to OFF button in series (Refer to figure. 2 and figure. 3)

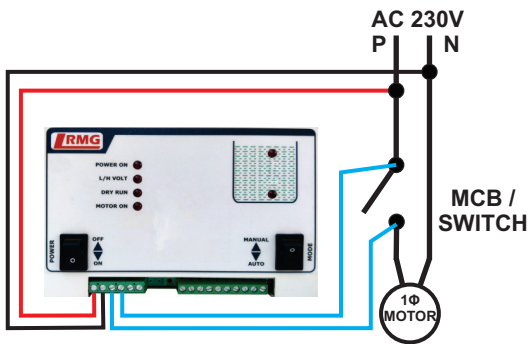

Figure1: 1Φ SWITCH/MCB

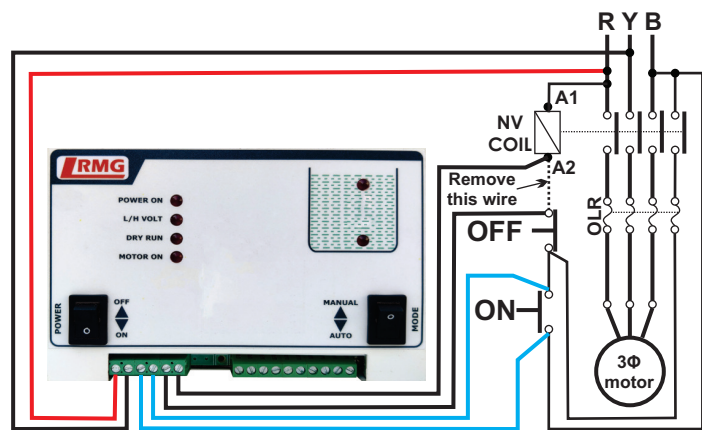

Figure2: 3Φ Starter

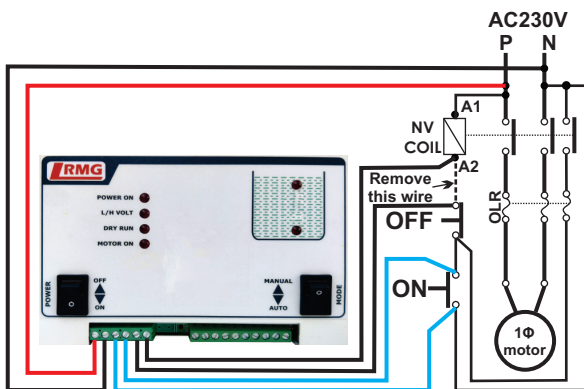

Figure3: 1Φ Starter

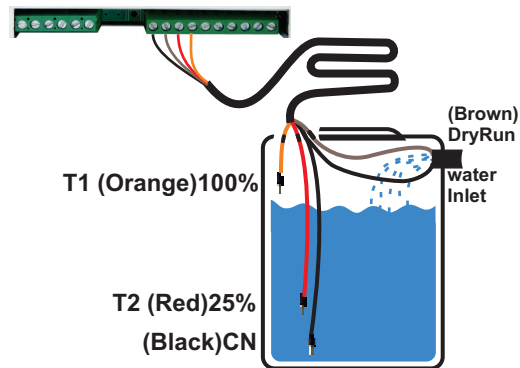

Figure4: sensor connection

Note: In case of doubts please call 044 - 43180017 or What's App 9940594413 from Monday to Saturday 10 am to 6 pm.

Step 5: Lay 6 core cable between controller and tank. Join one end of the 6 core cable to sensor line connector of controller as per label. In tank side, **Contact type sensor connection:** Take the sensors and cut them according to the levels of tank and join them with the 6 core cable as per label coded. (Refer figure. 4) **Magnetic float sensor connections:** These Sensor has 2 wires, Use any one wire in each sensor as common. Other wires left in each can be used for levels. Join them with the 6 core cable as per label coded.

Step 6: Immerse the Sensors inside the Over Head Tank (OHT) and tape it. Sensors should be in 25% and 100% of tank. Dry run sensor should be fixed in the inlet of the tank. (Refer figure. 4)

This completes installation.

5. OPERATING PROCEDURE

- Keep the Manual/Auto mode switch in Auto mode for automatic operation.
- Turn on the Power On/OFF switch. Power ON LED will glow.
- Depending upon the water level in tank, level indicator LEDs will be ON.
- When tank level goes below 25%, controller turns ON the motor. Then MOTOR ON LED will glow.
- When tank is full and reaches 100% controller turns OFF the motor and MOTOR ON LED will be OFF.

6. TROUBLE SHOOTING METHODS

#	Error	Solutions
1	Device dead / Not Powered ON	a. Check the fuse, If it is failed, please change 300mA fuse. b. If problem continues, send the product to the given address for service.
2	Tank level indicator LEDs are off	a. In the controller unit, join common terminal with a small wire to other terminals one by one and verify the tank LEDs are glowing. This means the controller unit is fine. b. Check the cables between controller and tank for cable breakage. If so correct it. c. Check common sensor and other sensor connections are correctly made. If any loose contacts correct it.
3	Dry run LED is ON continuously	Normally Dry Run LED will reset after 1 hour if dry run occurs, If it is not OFF a. Check whether water is coming in the inlet of the tank b. Check if any loose contacts present in the dry run connection and correct it. c. Check the cable between the controller and tank for cable breakage. If so, correct it.
4	L/H Voltage LED is ON continuously	a. Check whether voltage fluctuations are there in the input lines. b. L/H voltage LED resets after 1 minute, if the input lines becomes normal.