



RMG AUTOMATION

+91 9940594413

Street Light Timer

Model : SLT



User Manual

Version 2.1-09/23

1. INTRODUCTION

SLT is a real time and day based timer used to control any electrical device for the set time. It has a variety of application street light, garden light, factory light control, motor pump control etc.

SLT has 25 ON and OFF programmable time slots and can work in auto and manual modes of operation.

2. DESCRIPTION

- **Power ON/OFF switch:** This switch is provided at the bottom of the device to switch ON or switch OFF the controller.
- **Fuse:** Auto cut off in event of any excessive current.
- **Alpha numerical 2x16 LCD display:**
 - **Home Screen:** It will display the current date and day on the first line. It shows the current time and status on the second line
 - **Status in the LCD:** It includes Auto / Manual, Relay ON / OFF.
- **Menus:**
 - **Set Date / Time:** It helps to set the current date, month, year, hours, minutes and day.
 - **Set ON & OFF time:** It helps to set the ON & OFF time slots with day. Use SET & UP to set time and day.
 - **Mode:** It helps to select the AUTO / MANUAL operation. In AUTO mode, the timer works based on the set time. In MANUAL mode, NEXT and UP keys are used for switching ON /OFF operation.
 - **Change Password:** It helps to change / update the current password.
- **INPUT keys:**
 - **SET key:** It is used for entering the menu and to save the settings.
 - **NEXT key:** It is used for moving to the NEXT options like Menu, Successive Locations.
 - **UP key:** Used to set the values in date, time, and password.

3. TOOLS REQUIRED

- Multistrand power cable
- Insulation tape
- Wooden Gattas
- Line tester
- Wire stripper
- Simple hammer
- Drill gun
- Screws for mounting unit on wall

4. INSTALLATION PROCEDURE

Caution: Switch off the main power while doing the Power Connection steps.

Step 1: Wall mount the timer.

Step 2: Connect 230V AC supply to red and black wire of timer refer figure 1.

Step 3: Connect blue pair wire to the switch/MCB of the load in parallel as shown in figure 1.

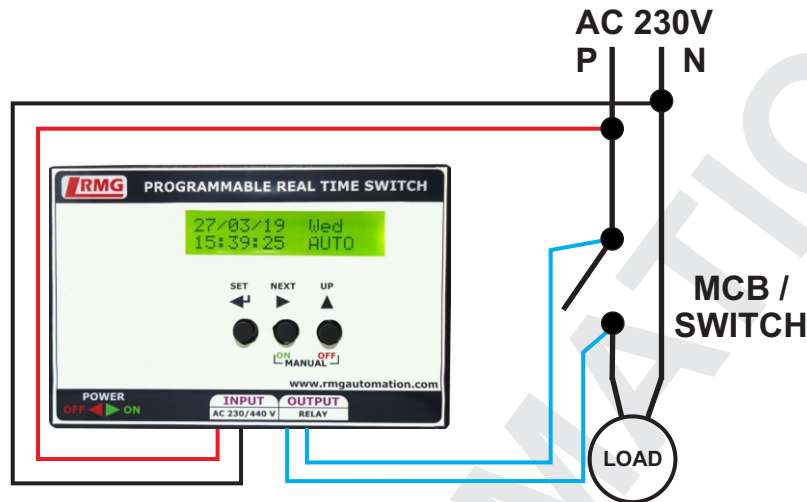

Figure1: POWER & LOAD CONNECTION

Note: In case of doubts in installation, please call 044 - 43180017 or What's App 9940594413 from Monday to Saturday 10 am to 6 pm.

5. OPERATING PROCEDURE

- Switch ON the device using the power ON/OFF switch. There is a power ON delay of 6 seconds.
- Using SET, NEXT and UP keys program the timer depending on your requirement. Refer **Programming methods** for more programming.
- Depending upon the program, Timer will ON/OFF the electrical device connected to it.
- You can **reset** the timer by pressing **NEXT** and **UP** buttons together.

6. TROUBLE SHOOTING METHODS

Sl. No.	Error	Solutions
1	Device dead / Not Powered ON	a. Check the power connection wires for loose contacts. b. If problem continues, contact RMG Automation for support
2	Load connected is not switching ON	a. Check whether the connections are given properly. b. If connections are okay and still issue persist, contact RMG Automation for support

5. PROGRAMMING METHODS

